

Strainer 800 lbs Y-type with screwed ends NPT



- Materials:** Body: forged steel A105N, Screen: perforated plate stainless steel AISI 316, Gasket: graphit reinforced
- Connection:** screwed ends NPT
- Test pressure:** 205 bar

DN	L	A	Mesh-width*	Weight (kg)	Article No.**
3/8"	90	60	0,80	1,00	0206555303800
1/2"	90	60	0,80	1,00	0206555301200
3/4"	110	75	0,80	1,20	0206555303400
1"	130	85	0,80	2,00	0206555304400
1 1/4"	160	120	0,80	6,00	0206555305400
1 1/2"	160	120	0,80	6,00	0206555306400
2"	160	160	0,80	7,00	0206555308400

* Fine screens at all nominal diameters mesh width 0,25 mm, free area 37%

** When ordering with fine screen: Article-Nr. + addition "with F-SIEB"

DN	L1	D1	Fo	KVS1	KVS2	Zet1	Zet2	ø G	ø R	P	D	B
3/8"	41	18	38 %	5,1	5,0	1,56	1,60	36	28,5	3,5	1/4"	85
1/2"	41	18	38 %	5,1	5,0	1,56	1,60	36	28,5	3,5	1/4"	85
3/4"	60	22	38 %	9,7	9,6	2,22	2,27	41	32,5	3,5	1/4"	135
1"	75	28	38 %	14,6	13,3	3,07	3,71	50	40,5	3,5	1/4"	170
1 1/4"	100,5	41,5	38 %	32,6	29,9	3,84	4,52	70	57	3,5	1/4"	230
1 1/2"	100,5	41,5	38 %	32,6	29,9	3,84	4,52	70	57	3,5	1/4"	230
2"	100,5	49,5	38 %	50,3	49,8	3,84	3,92	63	52,5	3,5	1/4"	240

The delivery of the strainer is in accordance to PED 2014/68/EU Point 11 and 12 of the preamble and article 1, clause c as well as article 4, clause 3.
The picture shown is only a symbolic photo! Subject to technical changes and errors.

Key for our datasheets

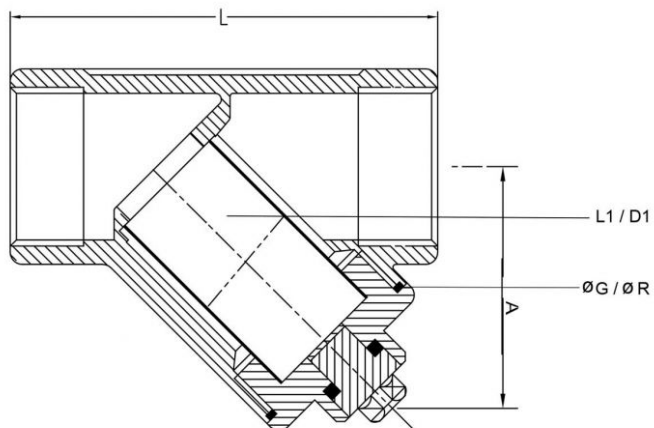

DN	Nominal diameter
L	Face to face dimension (mm)
A	Centre line of pipe to end of cover (mm)
L1	Screen length (mm)
D1	Screen diameter (mm)
Fo	Free screen area standard element (mm)
KVS1	KVS-Value standardscreen (m ³ /h)
KVS2	KVS-Value fine screen (m ³ /h)
Zet1	Zeta-Value standardscreen
Zet2	Zeta-Value fine screen
ø G	Outer-diameter coverflange gasket (mm)
ø R	Inner-diameter coverflange gasket (mm)
P	Thickness coverflange gasket (mm)
D	Coverflange size
B	Distance required to remove screen (mm)